

# BRISTAN

## Installation Instructions and User Guide

Claret Tap Range

### Models Covered:

CLR BASNW C/WHT  
CLR 1HBF C/WHT  
CLR WMBAS C  
CLR WMBF C/WHT  
CLR WMBSM C

**Please keep this booklet for future  
reference.**

Installer, when you have read these  
instructions please ensure you leave  
them with the user.

# Contents

Thank you for choosing Bristan, the UK's leading taps and showers expert.

We have designed this product with your enjoyment in mind. To ensure that it works to its full potential, it needs to be fitted correctly. These fitting instructions have been created to give you all of the information you need and, if you need any further help, please do not hesitate to contact us.

## Contents

- Important Safety Information **3**
- Specifications **4**
- Dimensions (mm) **5-6**
- Installation **7-12**
- Maintenance **13-14**
- Troubleshooting **15**

# Important Safety Information

- **Please read these instructions thoroughly and retain for future use.**

- All products manufactured and supplied by Bristan are safe provided they are installed, used correctly and receive regular maintenance in accordance with these instructions.

- **If you are in any doubt about your ability to install this product safely you must employ the services of an experienced qualified plumber/electrically qualified person.**

- This product has been tested to the Water Regulations Advisory Scheme (WRAS) and satisfies the requirements of the Water Supply (Water Fittings) Regulations 1999 and current bylaws. For full Installation Requirements & Notes (IRN) please visit [wras.co.uk/directory](http://wras.co.uk/directory).

-  **Warning:** Before starting any installation please consider the following: before drilling into walls, check that there are no hidden electrical wires, cables or water supply pipes. This can be checked with the aid of an electronic detector.

- If power tools are used do not forget to:
  - Wear eye protection
  - Unplug equipment after use

- **Important:** Remember to turn off the mains water supply before connecting to any existing pipe work.

-  **Warning:** Before installing the new fitting it is essential that you thoroughly flush through the pipework in order to remove any remaining swarf, solder, etc. Failure to carry out this procedure could cause problems or damage to the workings of the fitting.

- We recommend isolation valves to be fitted to the inlet water supplies to ensure ease of future maintenance.
- Full access must be made available for future maintenance/servicing purposes.
  - Take care when handling the 'flexible connecting pipes', do not bend, twist or crush them. Only tighten the pipes by hand.
  - Do not crush or kink the shower hose, this could damage the hose and cause leaks.

This product must not be modified in any way as this will invalidate the guarantee.

If in doubt, contact a registered plumber or your Local Water Authority or the Secretary of the Institute of Plumbing, address as follows:-

The Institute of Plumbing,  
64 Station Lane,  
Hornchurch,  
Essex,  
RM12 6NB, Tel: 01708 472791

# Specifications

Product Code	Working Pressure	
	Min	Max
1 Hole Bath Filler	1.5	5.0
Basin Mixer (No waster)	0.2	5.0
Wall Mounted Basin Mixer	1.0	5.0
Wall Mounted Basin Filler	0.3	5.0
Wall Mounted Bath Shower Mixer	1.0	5.0

Maximum static pressure- 10.0 bar

NOTE:- Nominally equal (balanced) inlet supply pressures are recommended for optimum Performance of mixer taps.

Designed to comply with BS EN 200 for single taps/ combination taps for water systems of type 1 and 2 general technical specifications; and to be used within systems designed to BS 6700.

BS 6700 recommends the temperature of stored water should never exceed

65° C. A stored water temperature of 60° C is considered sufficient to meet all nominal requirements and will minimise the build up of lime scale in hard water areas.

# Dimensions (mm)

Basin Mixer

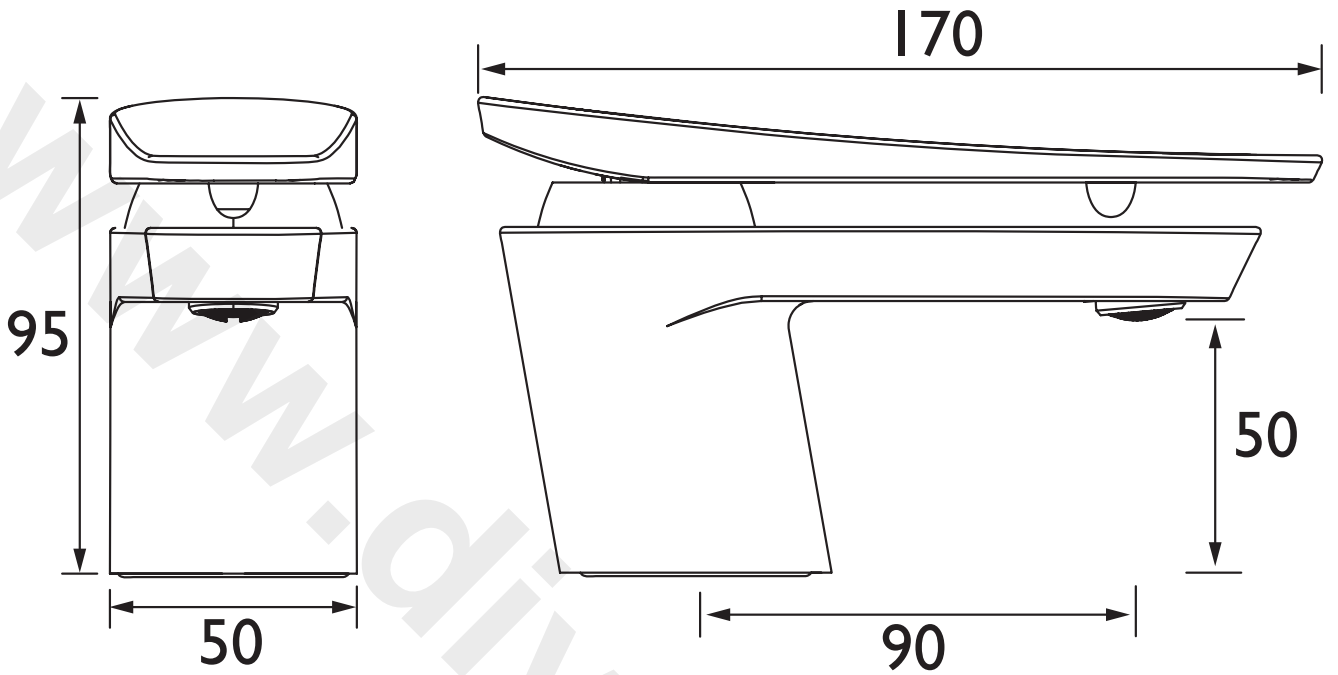

1 Hole Bath Filler

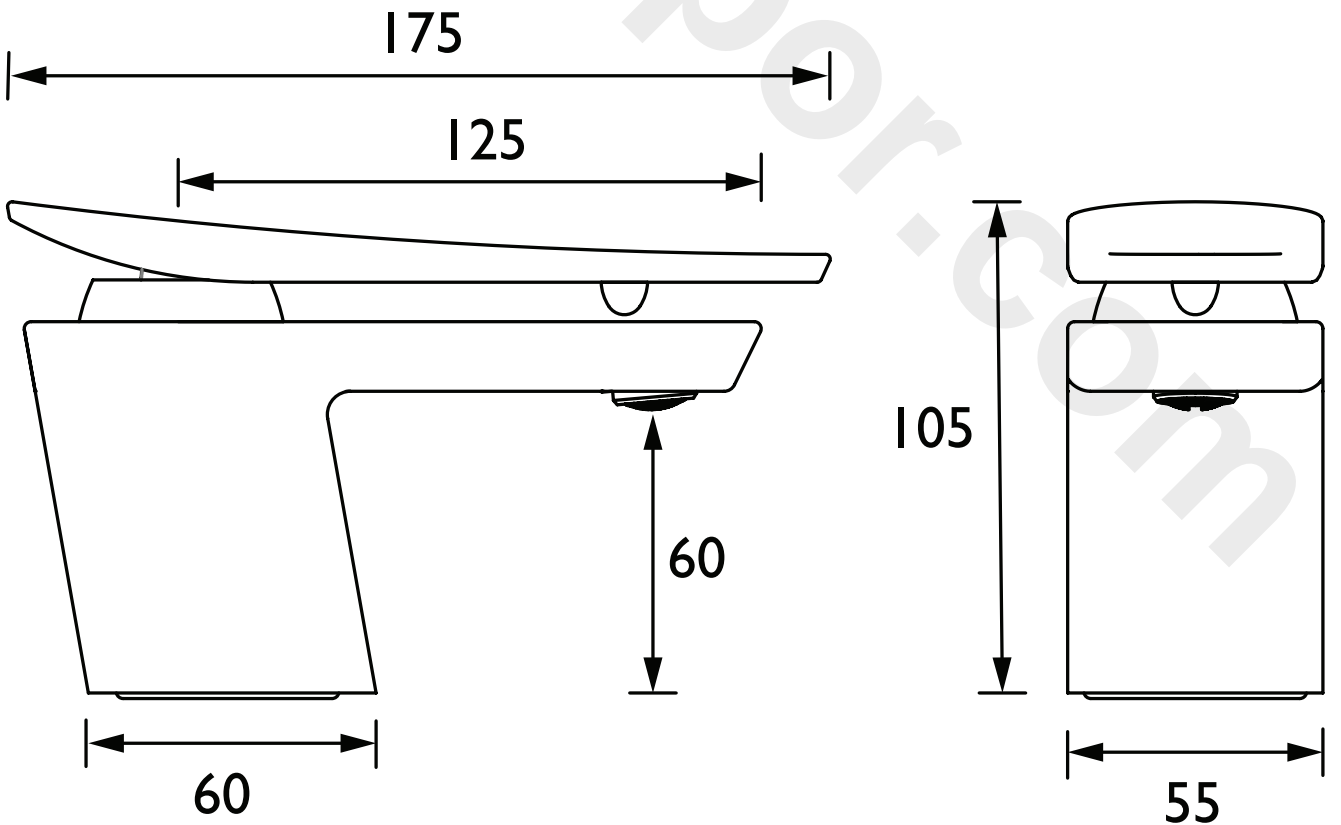

# Dimensions (mm)

Wall Mounted Basin Mixer

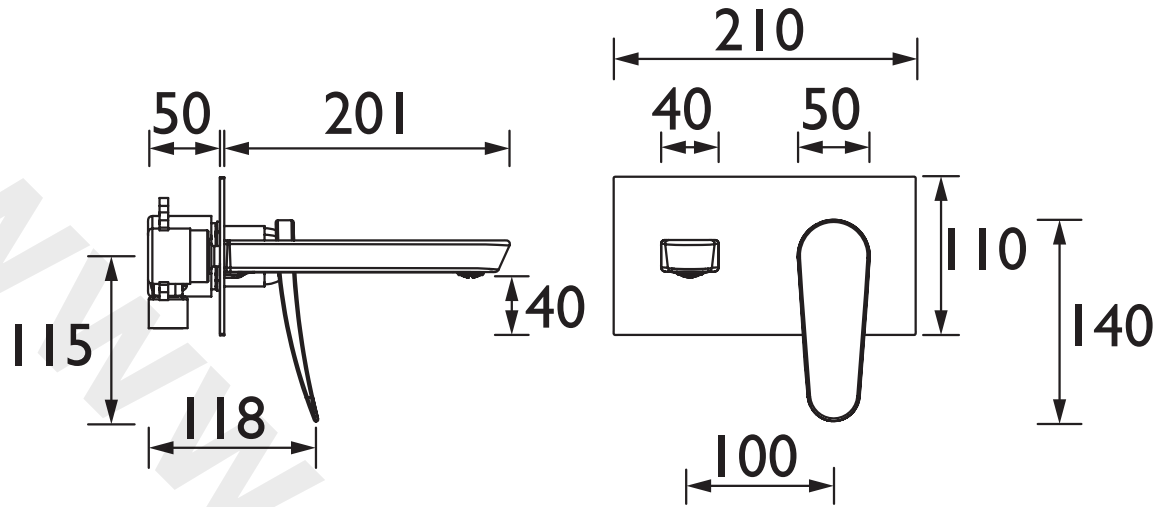

Wall Mounted Bath Filler

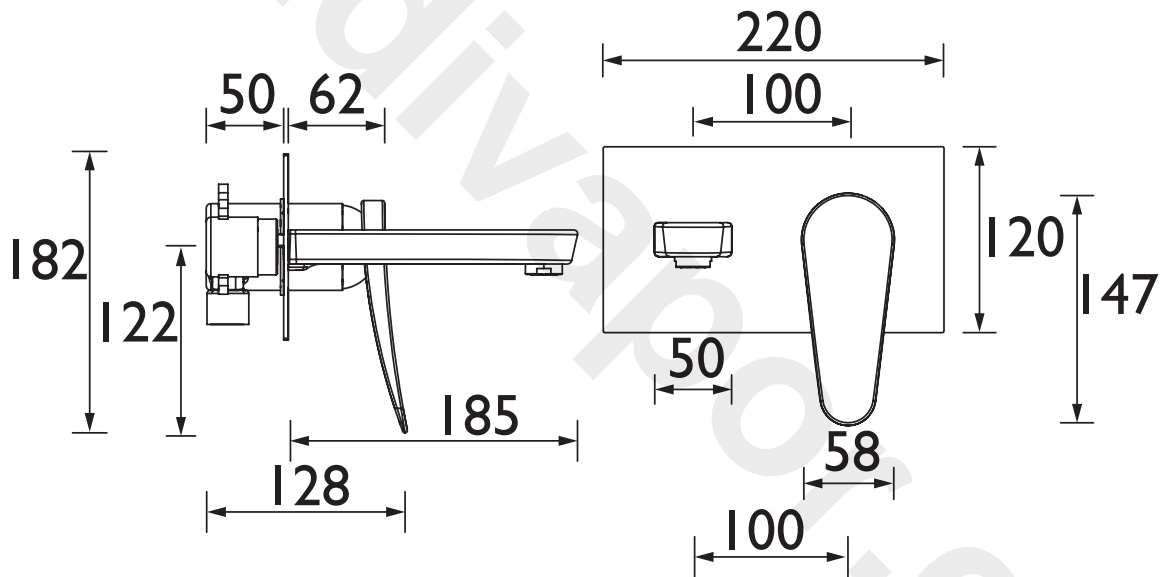

Wall Mounted Bath Shower Mixer

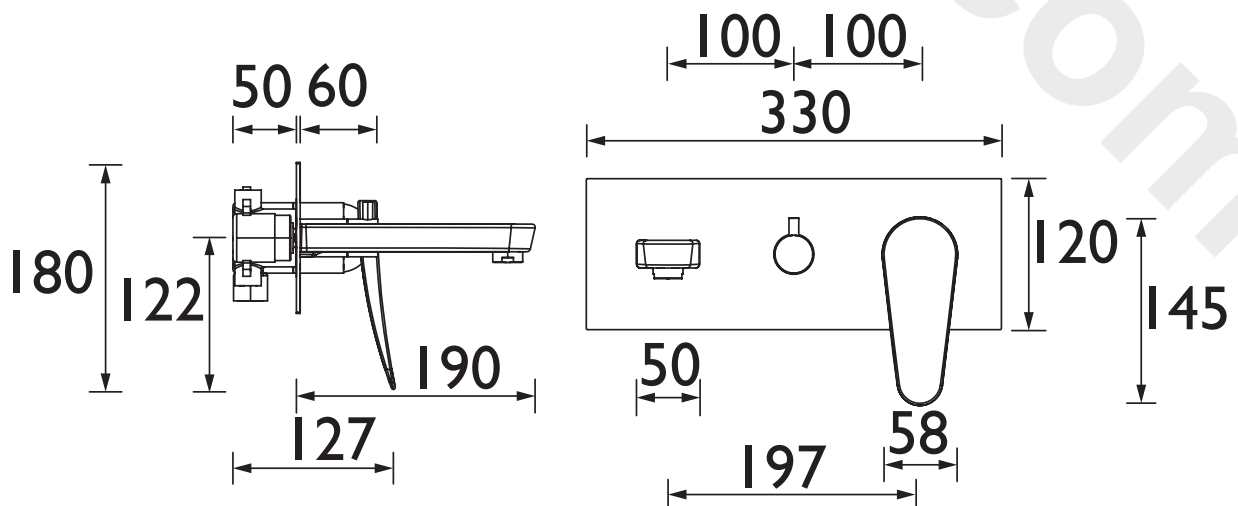

# Installation

## Basin Mixer (No Waste) & 1 Hole Bath Filler

1. Grub Screw	x1
2. Lever Handle	x1
3. Lever Handle Spacer	x1
4. Shroud	x1
5. Cartridge Retaining Nut	x1
6. Cartridge	x1
7. Tap Body	x1
8. Anti-Splash Assembly	x1
9. Washer	x1
10. 'C' Shaped Rubber Washer	x1
11. 'C' Shaped Metal Plate	x1
12. Fixing Rods	x2
13. Connecting Pipes	x2

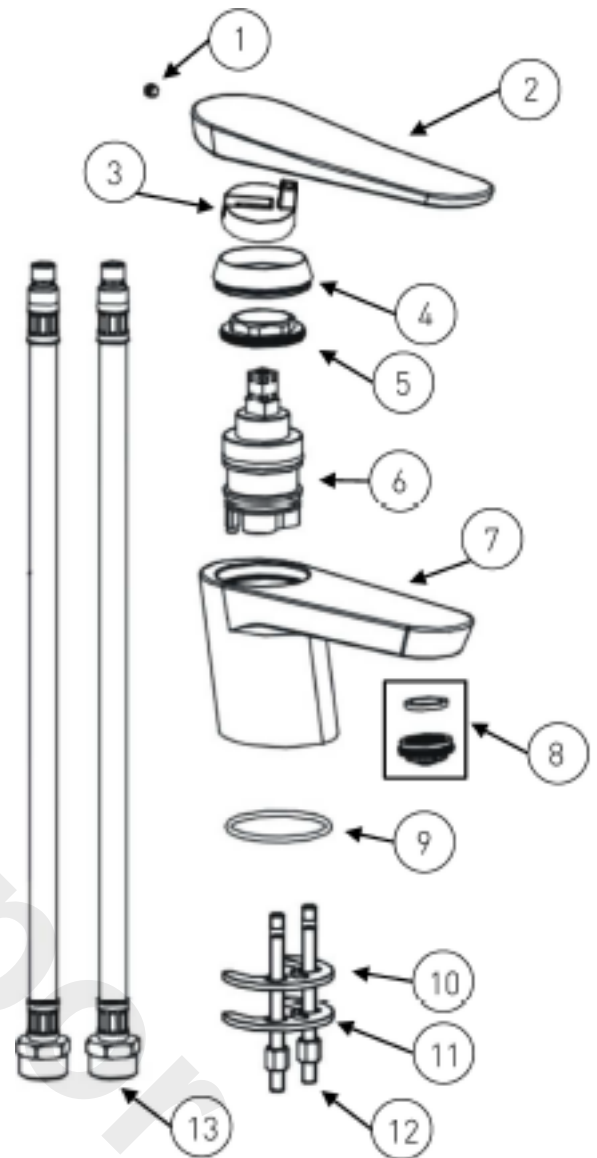

1. Identify all components are present prior to starting installation.
2. Ensure that the washer (9) is fitted to the underside of the tap body (7) before fitting to the basin/bath. Secure the 'C' shaped rubber washer (10) and metal plate (11) into position on the underside of the basin/bath, using the threaded rods and nuts (12).
3. Fit the inlet connection pipes (13) by hand only (DO NOT OVERTIGHTEN) to the fitting and connect the hot and cold supplies.
4. Connect the hot and cold water supplies to the connecting pipes.
5. Turn on the water and fully open the mixer, allowing it to run for a few minutes and check all joints and connections for any leaks.

# Installation Cont.

## Wall Mounted Basin Mixer/ Bath Filler

1. Handle	x1	11. O-Ring	x1
2. Cartridge Retaining Nut	x1	12. Screw & Wall Plug Pack	x1
3. Shroud	x1	13. Nut & Olive	x1
4. Cartridge	x1	14. Spout Connection Kit	x1
5. Mixer Body Sleeve	x1	15. Locking Grub Screws	x2
6. O-Ring	x1	16. Spout Grub Screw	x1
7. Mixer Body	x1	17. Spout	x1
8. Concealing Plate	x1	18. Anti-Splash	x1
9. Concealing Plate	x1	19. Handle Grub Screw	x1
10. O-Ring	x1		

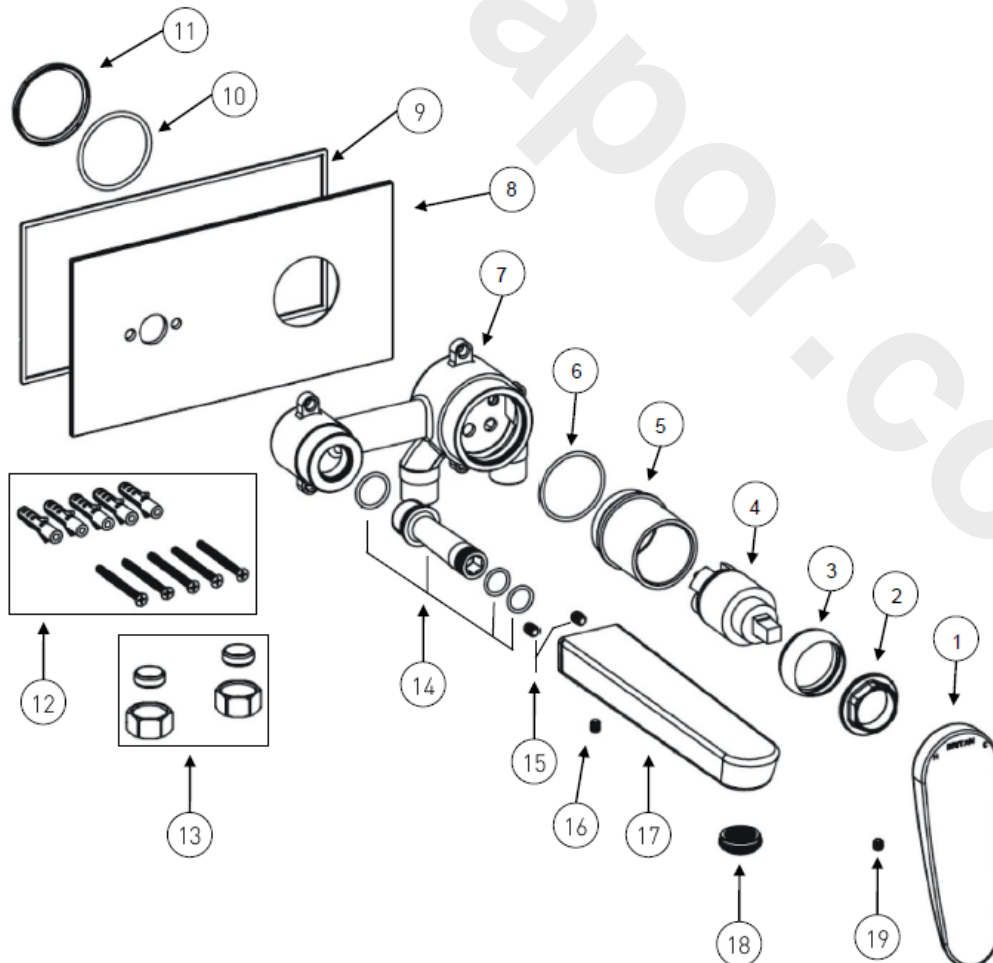

# Installation Cont.

## Wall Mounted Basin Mixer/ Bath Filler

1. Identify all components are present prior to starting installation using the diagram overleaf, and be sure to refer to the dimensions on pages 4 & 5 for minimum and maximum wall cavity depths.
2. Offer the mixer body (7) up to the wall and once in the desired position, mark and drill holes for the fixings (12)
3. Fit the mixer body (7) to the wall and connect water supplies using the nut and olive (13). Any further tiling required, should be completed at this stage.
4. Push concealing plate (8). complete with seal (9), over the valve body and push towards the tiled surface.
5. Push the spout (17) on to the pre-fitted spout connection kit (14); ensuring that both O-rings locate within the spout, and both of the locking grub screws (15) fit into place, via the 2 small holes in the concealing plate (8). Tighten grub screw on the underside of spout to secure into place.
6. Turn on the water and fully open the mixer, allowing it to run for a few minutes and check all joints and connections for any leaks

**IMPORTANT:** Before drilling into walls, check that there are no hidden electrical wires, cables or water supply pipes. This can be checked with the aid of an electronic detector. If power tools are used do not forget to wear eye protection & unplug equipment after use.

**NOTE:** The tiles should not restrict access to the valve in order to allow for servicing of the product if necessary.

**TIP:** Use a thin line of silicone based sealant around the back edge of the concealing plate to create a tight water seal.

# Installation Cont.

## Wall Mounted Bath Shower Mixer

1. Handle	x1	13. Hose	x1
2. Shroud	x1	14. Handset	x1
3. Retaining Nut	x1	15. Spout Connections	x1
4. Cartridge	x1	16. Spout Locking Pins	x1
5. Sleeve	x1	17. Spout	x1
6. O-Ring	x1	18. Grub Screw	x1
7. Mixer Body	x1	19. Anti-Splash	x1
8. Concealing Plate	x1	20. Diverter Assembly	x1
9. Plate Seal	x1	21. Diverter Knob	x1
10. O-Ring	x1	22. Grub Screw	x1
11. O-Ring	x1	23. Screw & Wall Plug Pack	x1
12. Handset Holder	x1	24. Nut & Olive	x3

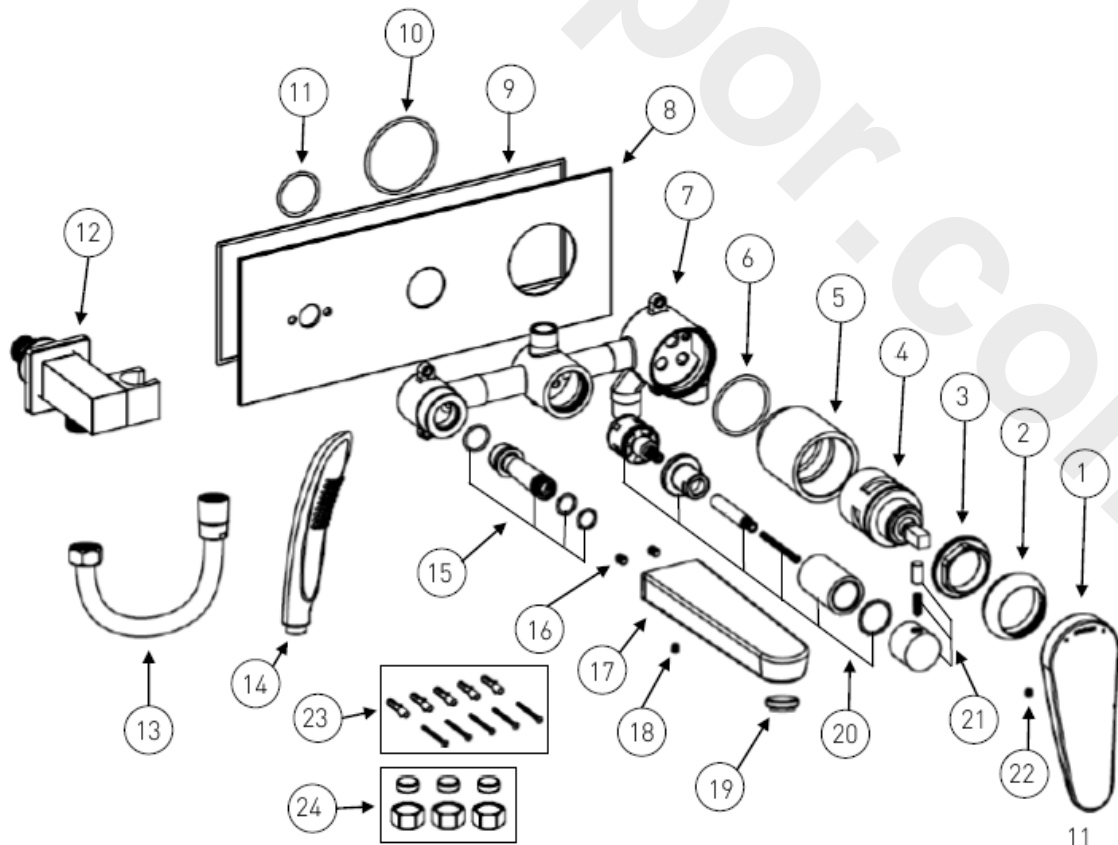

# Installation Cont.

## Wall Mounted Bath Shower Mixer

1. Identify all components are present prior to starting installation using the diagram overleaf, and be sure to refer to the dimensions on pages 4 & 5 for minimum and maximum wall cavity depths.
2. Offer the mixer body (7) up to the wall and once in the desired position, mark and drill holes for the fixings (23)
5. Push the spout on to the body ensuring both O-rings locate within the spout, and both locking pins (16) lock into place, via the 2 small holes on either side of the spout connection. Tighten grub screw on the underside of spout to secure into place.

**IMPORTANT:** Before drilling into walls, check that there are no hidden electrical wires, cables or water supply pipes. This can be checked with the aid of an electronic detector. If power tools are used do not forget to wear eye protection & unplug equipment after use

3. Fit the mixer body(7)to the wall and connect water supplies using the nuts and olives (24); and install the wall outlet connection (see page 13)

**NOTE:** Any further tiling required, should be completed at this stage, The tiles should not restrict access to the valve in order to allow for servicing of the product if necessary.

4. Push concealing plate (8), complete with seal (9). over the valve body and up towards the tiled surface.

**TIP:** Use a thin line of silicone based sealant around the back edge of the concealing plate to create a tight water seal.

**NOTE:** This fitting incorporates a diverter feature. Simply turn the diverter knob via the lever, in order to change the setting from handset only [upright position], a combination of handset and bath fill [central position], and bath fill only [downwards position].

# Installation Cont.

## Wall Outlet

There are two methods of fixing the wall outlet depending on the type of wall.

A. With rear access once wall is finished:

Remove the brass backnut from the threaded tail, and insert the wall outlet through a 25-30mm hole in the wall and secure with backnut.

**TIP:** Use a thin line of silicone based sealant around the back edge of the concealing plate to create a tight water seal.

Connect the wall outlet assembly to the shower valve outlet (connection not supplied).

B. Without rear access once wall is finished:

Fit a 'wall plate elbow' (not supplied) within the wall cavity and plumb in from the shower valve. Screw the threaded connecting tube (3) into the 'wall plate elbow' using a suitable thread sealant. The threaded connecting tube thread (3) must protrude from the finished wall by 5-15mm. Once the wall has been finished the wall outlet (4) and washer (2) can be fitted to the threaded connecting tube, using a suitable thread sealant.

**NOTE:** The backnut (1) is not required

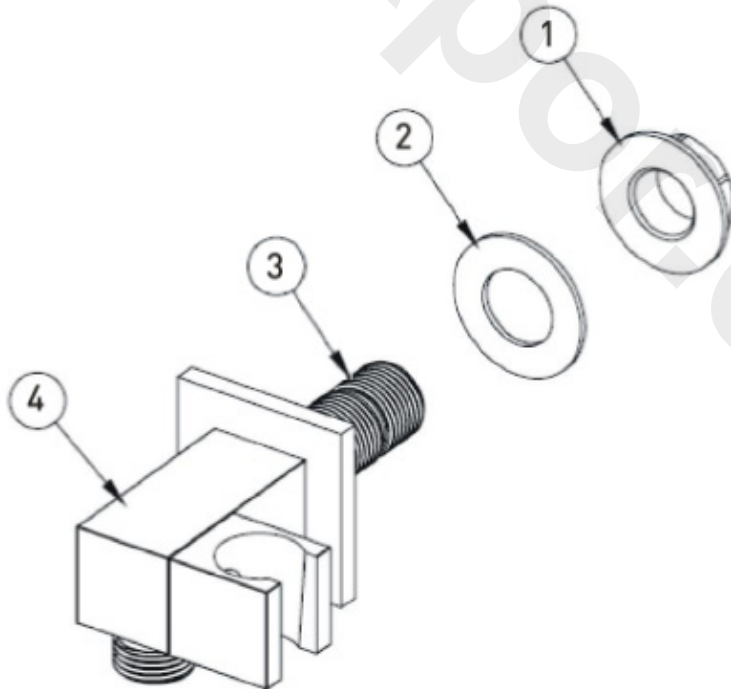

# Maintenance

## General Cleaning

Your fitting has a high quality finish and should be treated with care to preserve the visible surfaces. All finishes will wear if not cleaned correctly. The only safe way to clean your product is to wipe with a soft damp cloth. Stains can be removed using washing up liquid. All bathroom cleaning products (powders and liquids) will damage the surface of your fitting, even the non-scratch cleaners.

**Note:** Never use abrasive detergents or disinfectants or those containing alcohol, hydrochloric acid or phosphoric acid.

## Cleaning the Showerhead: CLR WMBSM C

Your Bristan showerhead has rub-clean nozzles for easy cleaning. Simply rub your fingers across the rubber spray jets regularly and before you turn the shower on to remove any scale or debris.

The hardness of the water in your area will determine how often you should clean your showerhead. Build up of scale in particularly hard water areas combined with constant use means you may need to clean your showerhead once a week. To ensure continued performance the showerhead needs to be regularly descaled.

Tip: If the showerhead is heavily scaled or has not been maintained for a long period of time a solution of hot water and white vinegar may be needed to clear the scale.

Mix a 50/50 solution and rub the nozzles thoroughly with the solution making sure the solution gets into all of the nozzles.

Wash off the solution with clean water.

# Maintenance Cont.

## Cleaning the Cartridge

If your fitting begins to leak the following should be carried:

Isolate both hot and cold water supplies to the tap by either:

- Turning the water supply off at the mains stopcock or
  - Turning off the isolation valves to the tap.
1. Remove the grub screw, located at the rear of the handle using a hexagonal key.
  2. Remove the handle by pulling upwards from the spacer; proceed to remove spacer and shroud.
  3. Using a suitable spanner remove retaining nut to gain access to the cartridge.
  4. Lift out the cartridge and clean thoroughly. Be sure to check and clean out the seating within the tap body.
  5. If necessary replace the cartridge.
  6. Place the cartridge into the tap body and tighten the retaining nut fully using a suitable spanner.
  7. Replace Shroud, spacer and handle ensuring to refit grub screw.
  8. Turn on water supply and check for leaks.

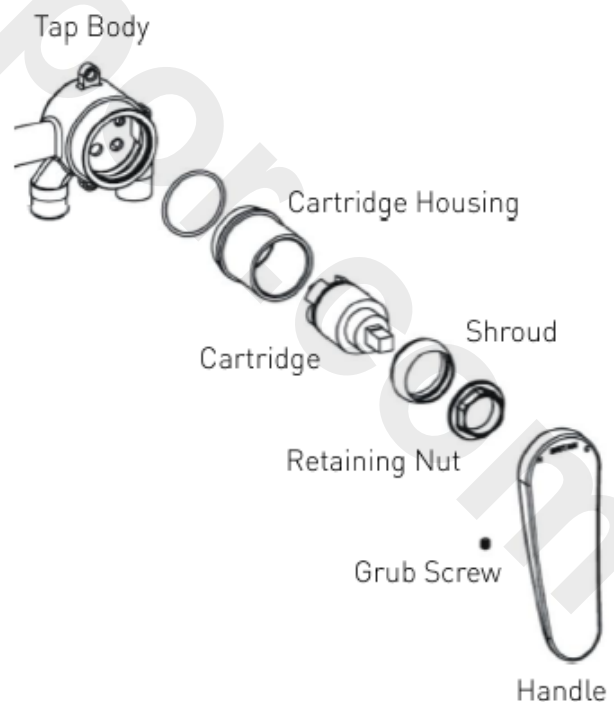
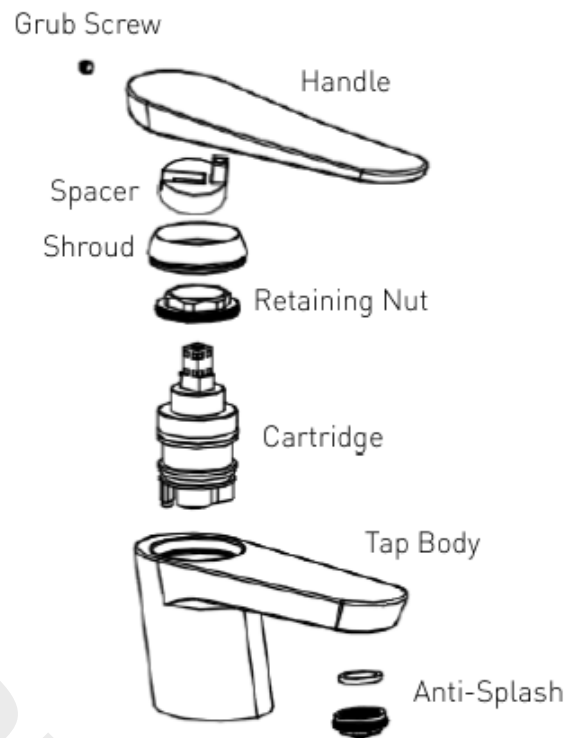

# Troubleshooting

Symptom	Cause	Remedy
No flow or poor flow rate.	Partially closed stop or service valve in water supply pipework to the tap.	Open stop or service valve.
	Head of water is below the minimum distance required.	Refer to the specification section for minimum pressures required.
	Possible airlock/ blockage in supply pipework	Remove water supplies from the fitting and flush the system to remove any airlocks/debris
	Cartridge not opening fully.	Service fitting. Refer to maintenance section.
Water dripping for a few seconds after the tap has turned off.	This is caused by 'capillary action' and residual water in the spout being siphoned out. This should only last for a couple seconds	
Constant dripping for a few seconds after the tap has been turned off.	Cartridge/ Valve not fully shutting off.	Service fitting and replace cartridge. Refer to maintenance section.
Fitting does not turn on.	Water supplies not turned on.	Check that the water supplies to the fitting are turned on.
	Closed stop or service valve.	Open stop or service valve.
Water does not come out of the showerhead when using the bath shower mixer.	Diverter mechanism not fully open.	Turn the diverter mechanism into the appropriate position.
	Insufficient water pressure/ header height.	Refer to the specification section for minimum pressures required.

Issue: D6

Part Number: CLARETTAPRANGE

## **BRISTAN**

### **Bristan Group Ltd.**

Birch Coppice Business Park

Dordon

Tamworth

Staffordshire

B78 1SG

**Web:** [www.bristan.com](http://www.bristan.com)

**Email:** [enquire@bristan.com](mailto:enquire@bristan.com)

### **A Masco Company**

At Bristan, we want to make things as easy as possible for our customers. That's why we offer solid guarantees on all our products, effective from the date of purchase, to give you peace of mind.

To start your free guarantee simply scan the QR code and register your product.  
Alternatively visit [www.bristan.com/register](http://www.bristan.com/register).

For any other queries, please call our Customer Service on 0330 026 6273 where our expert team of advisors will be able to offer you any help and advice.

For full guarantee terms and conditions visit [www.bristan.com/guarantees](http://www.bristan.com/guarantees).



*We Know & We Care*